

REVISIONS				
P.	LTH	DESCRIPTION	DATE	DMN APVD
C		REV PER ECO-15-012764	12OCT2015	KG DM

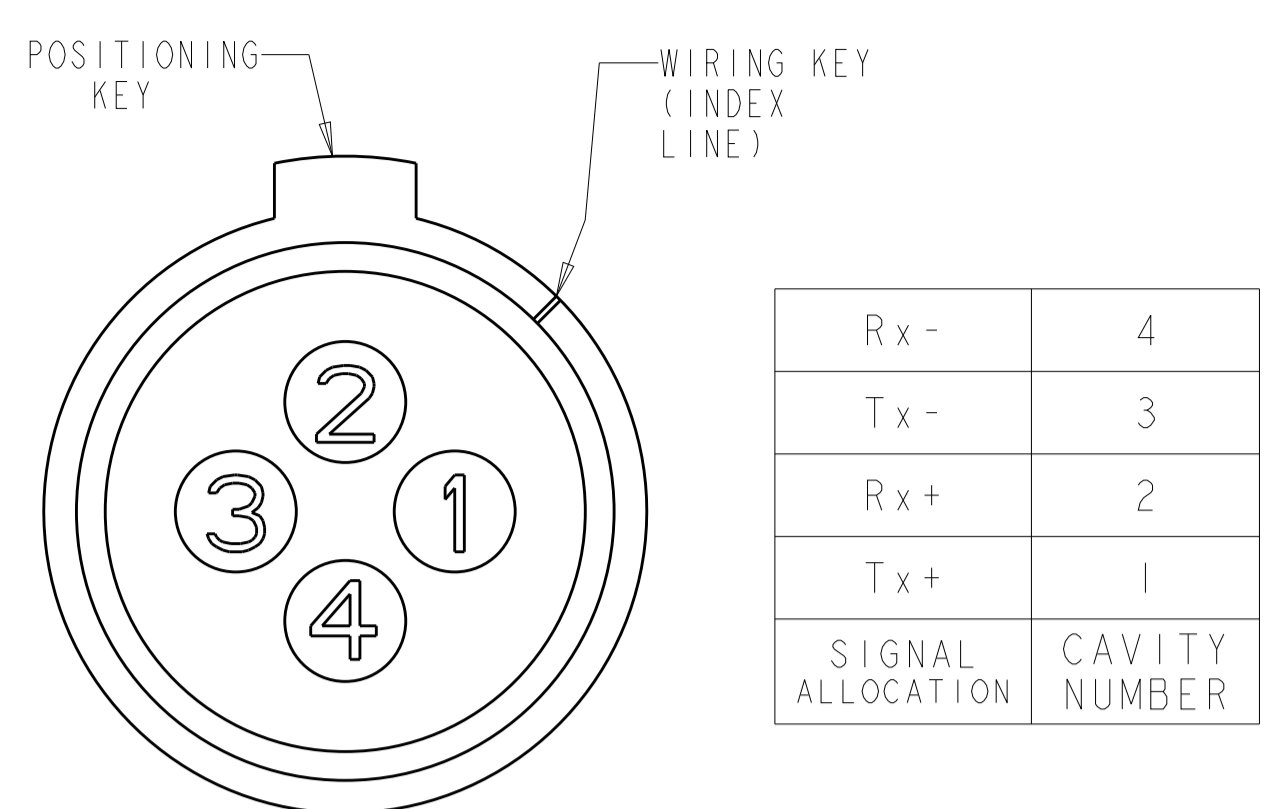

Rx-	4
Tx-	3
Rx+	2
Tx+	1
SIGNAL ALLOCATION	CAVITY NUMBER

MATING FACE VIEW  
 CONTACT CAVITY NUMBERING  
 STANDARD CAVITY NUMBER ASSIGNMENT

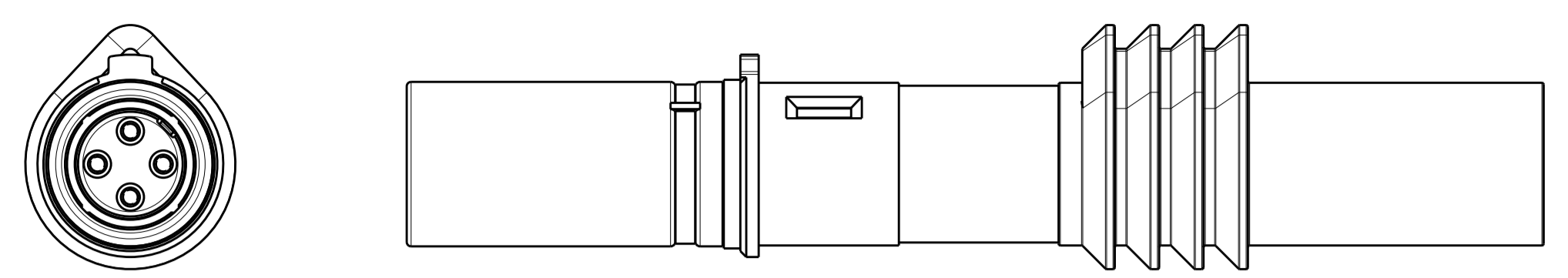

1877040-2  
 SCALE 4:1

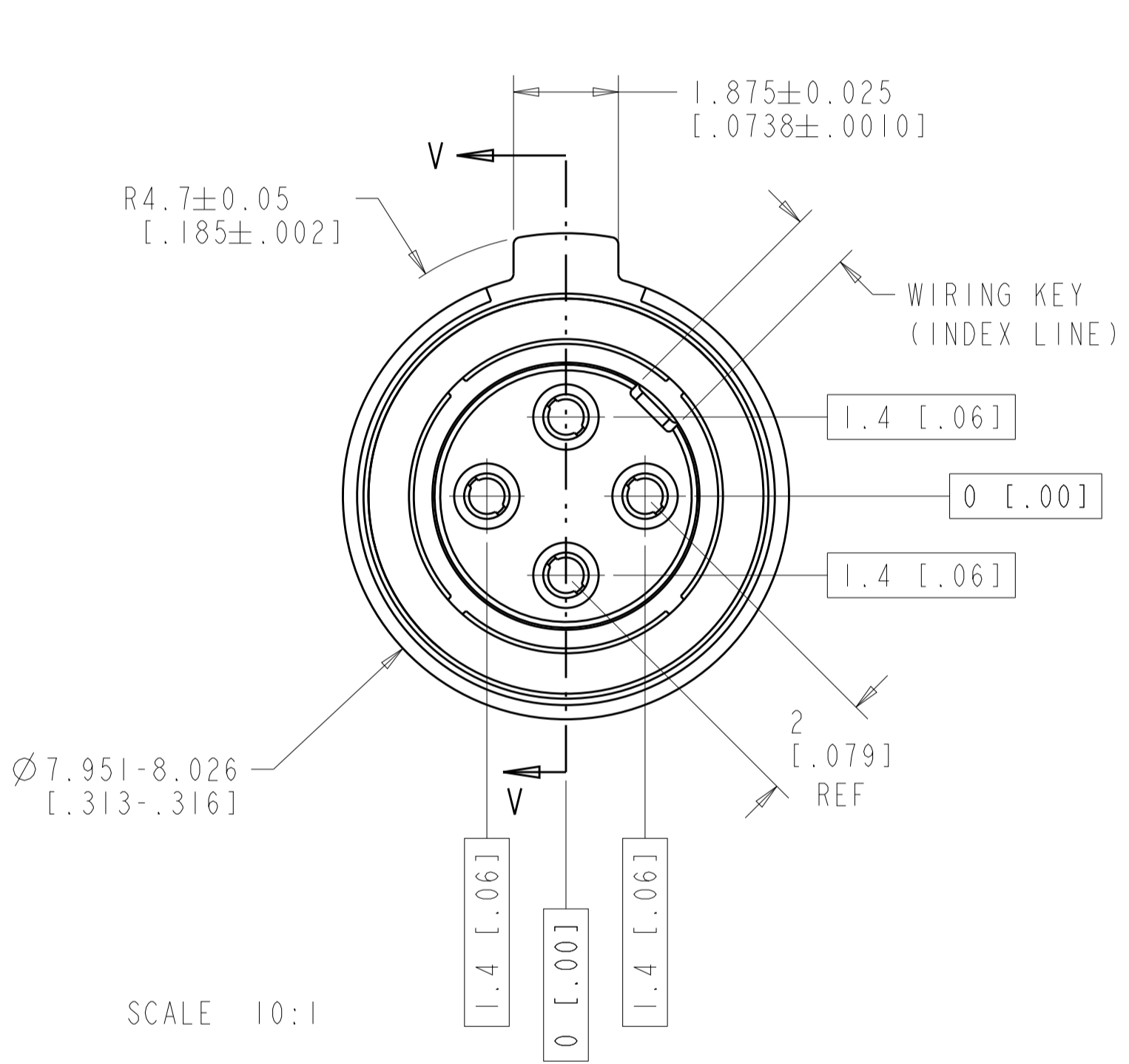

SCALE 10:1

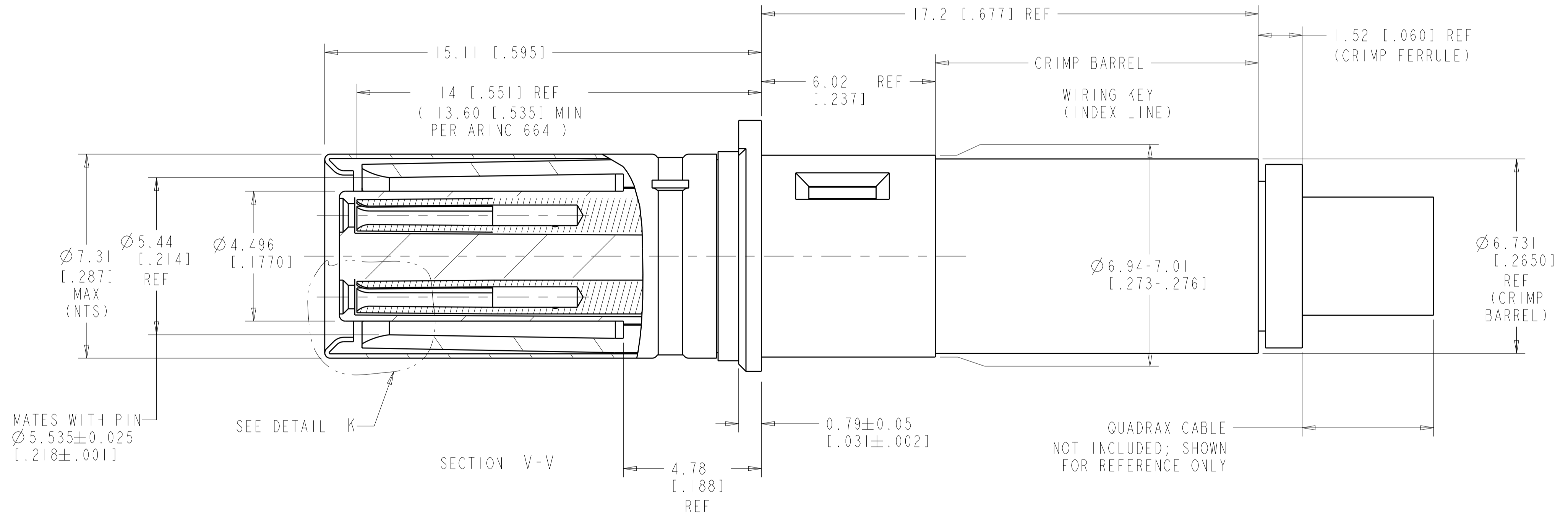

MATES WITH PIN  
 Ø5.535±0.025  
 [0.218±0.001]

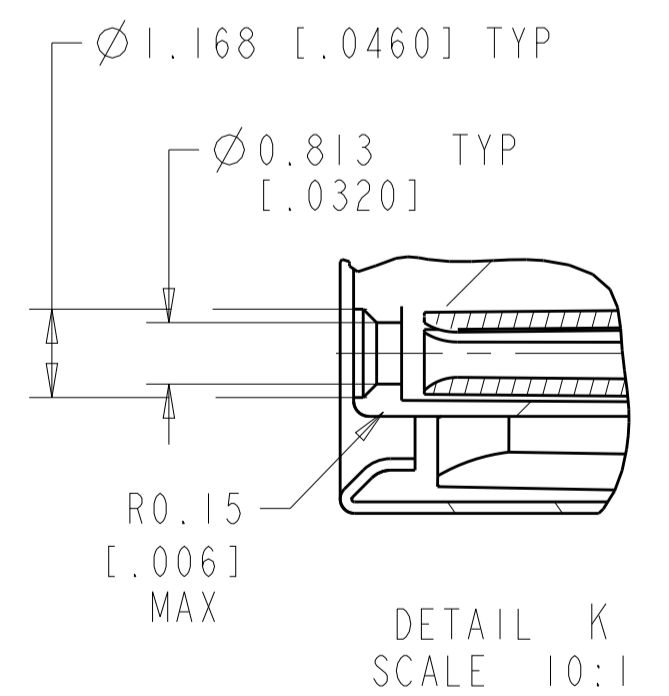

DETAIL K  
 SCALE 10:1

- COMPONENTS ARE PACKAGED IN KIT FORM. CABLE MUST BE PURCHASED SEPARATELY. .231 HEX CRIMP WILL ALLOW ASSEMBLY OF SOME 150 OHM CABLES. REFERENCE CABLES: TENSOLITE 26473/02006X-4(LD), RAYCHEM CEC-RWC-18684, RAYCHEM CEC-RWC-18680
- ASSEMBLY PER APPLICATION SPECIFICATION 114-13123. (.231 HEX CRIMP)
- USE INSERTION-EXTRACTION TOOL 1738894-1.

BLUE	SAME AS -1 EXCEPT WITH WIRE SEAL	1877040-2
--	AS SHOWN; WITHOUT WIRE SEAL	1877040-1
SEAL COLOR	DESCRIPTION	PART NO.

THIS DRAWING IS A CONTROLLED DOCUMENT.

DIMENSIONS: mm [INCH]	TOLERANCES UNLESS OTHERWISE SPECIFIED: 0 PLC ±.013 [0.005] 1 PLC ±0.2 [0.008] 2 PLC ±0.13 [0.0051] 3 PLC ±0.051 [0.002] 4 PLC ±.013 [0.005] ANGLES ±.013 [0.005]	DMN 05MAY05 CHK 05MAY05 RW 05MAY05 APVD 05MAY05	NAME ASSEMBLY, SOCKET, QUADRAX, 2mm SQ, AIRCRAFT DATA NETWORK, RR/RR WITH SOCKET CONTACTS, .231 HEX CRIMP
MATERIAL	FINISH	WEIGHT	RESTRICTED TO
CUSTOMER DRAWING		SCALE 10:1	SHEET 1 OF 2 REV C

STE TE Connectivity

THIS DRAWING IS UNPUBLISHED. RELEASED FOR PUBLICATION 20  
COPYRIGHT 20 BY - ALL RIGHTS RESERVED.

REVISIONS				
P.	LTN	DESCRIPTION	DATE	APVD
--		SEE SHEET 1	-	-

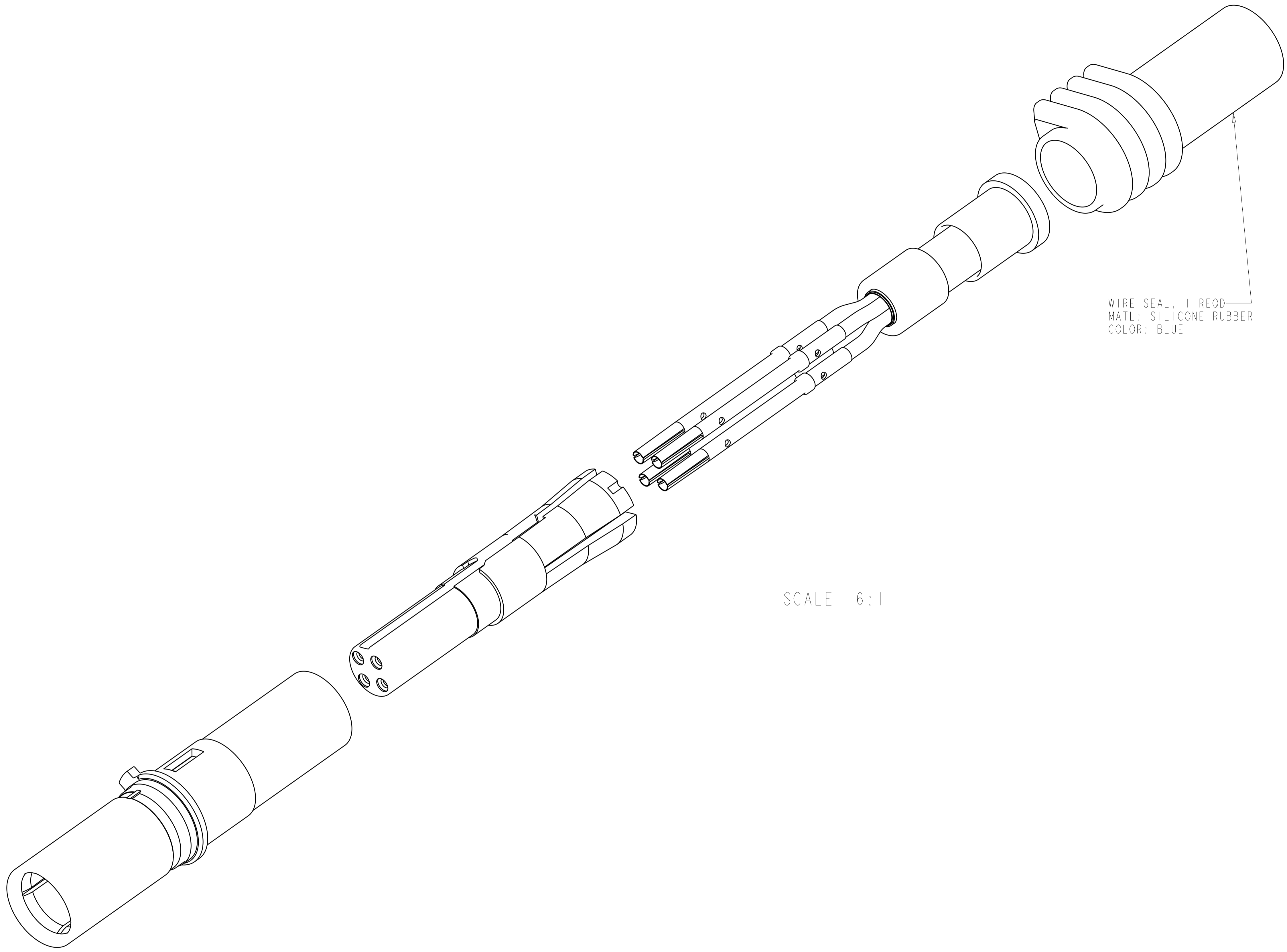

SCALE 6:1

THIS DRAWING IS A CONTROLLED DOCUMENT.		DWN: 05MAY05	
		CHK: 05MAY05	
		RW: 05MAY05	
		APVD: 05MAY05	
DIMENSIONS:	TOLERANCES UNLESS OTHERWISE SPECIFIED:	PRODUCT SPEC	<b>NAME</b> ASSEMBLY, SOCKET, QUADRAx, 2mm SQ, AIRCRAFT DATA NETWORK, RR/RR WITH SOCKET CONTACTS, .231 HEX CRIMP
mm [INCH]	0 PLC ± 1 PLC ±0.2 (1.008) 2 PLC ±0.13 (1.0051) 3 PLC ±0.051 (1.002) 4 PLC ± ANGLES ± FINISH ±	APPLICATION SPEC	
MATERIAL		WEIGHT	<b>SIZE</b> A1 <b>CAGE CODE</b> - <b>DRAWING NO</b> C=1877040
		CUSTOMER DRAWING	<b>SCALE</b> 4:1 <b>SHEET</b> 2 <b>OF</b> 2 <b>REV</b> C